

1 General

Fan diameter Ø:	130 mm
Nominal voltage:	12 V
Drive family	SBL40
Part number:	30107288

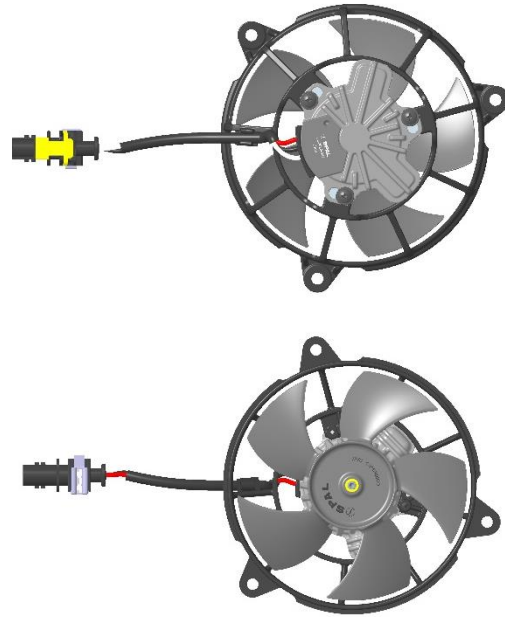

2 Features

Max fan speed	rpm	5200
Min fan speed	rpm	1300
Sound pressure level at max speed	dBA	60 – at 1 m from the fan module - lateral side
Weight	kg	0.46
Operating supply voltage range	V	9.0 .. 16.0 at the Drive connector
Supply voltage to reach max speed	V	13.0 .. 16.0 at the Drive connector
Operating ambient temperature range	°C	-40 .. +120
Max operating ambient temperature @ max fan speed	°C	+105 (1)
Storage temperature range	°C	-40 .. +125
Lifetime	h	up to 40000 hours depending on mission profile
Time from 0 rpm to max speed	s	8
Load dump protection (Pulse 5b)	V	35 - Pulse peak voltage (U _s [*]) - ISO16750-2:2010
Reverse polarity protection		No reverse polarity protection
Notes: (1) Few minutes ambient temperature transients do not engage the derating owing to the thermal inertia of the system. Overloads may anticipate derating.		

Any unauthorized use and / or copy of this document is strictly forbidden

3 Air performance at maximum speed

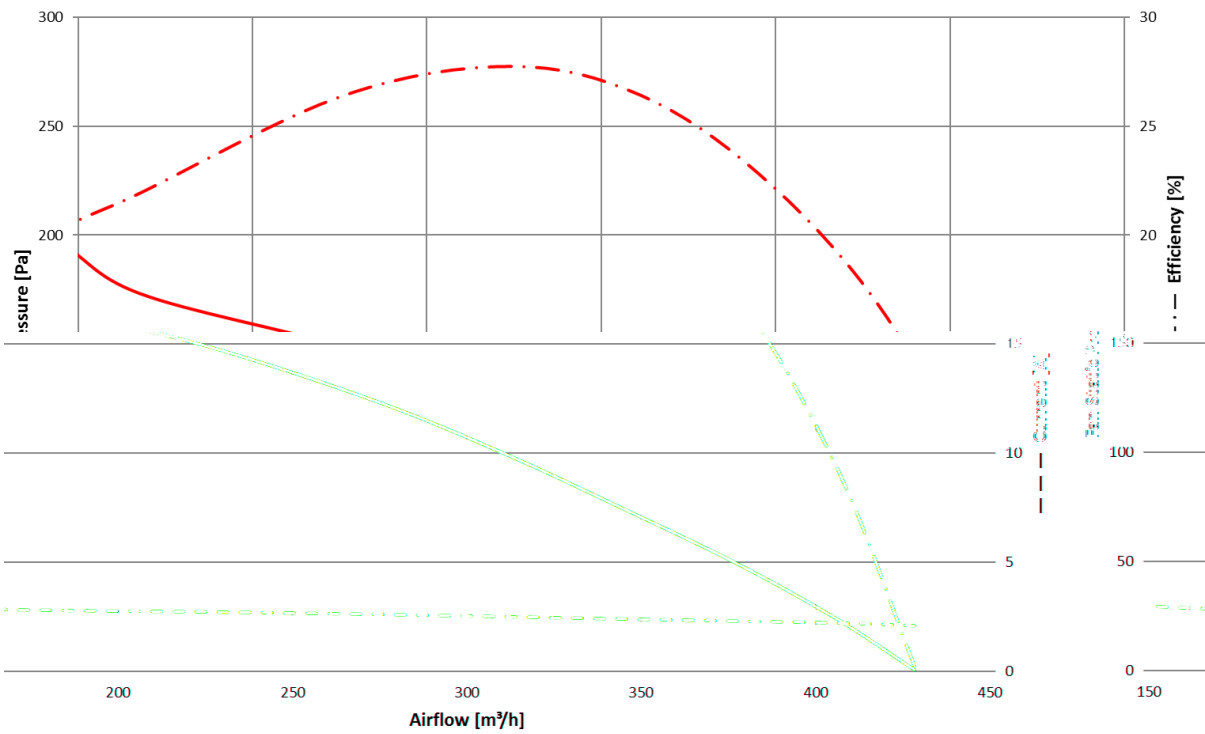

Air density 1.17 kg / m³ - Test number: #16804 – Test bench compliant to ANSI AMCA 210
 TAMB = 20 °C ± 5 °C - UB = 13.0 V at the Drive connector

Any unauthorized use and / or copy of this document is strictly forbidden

4 Mechanical data

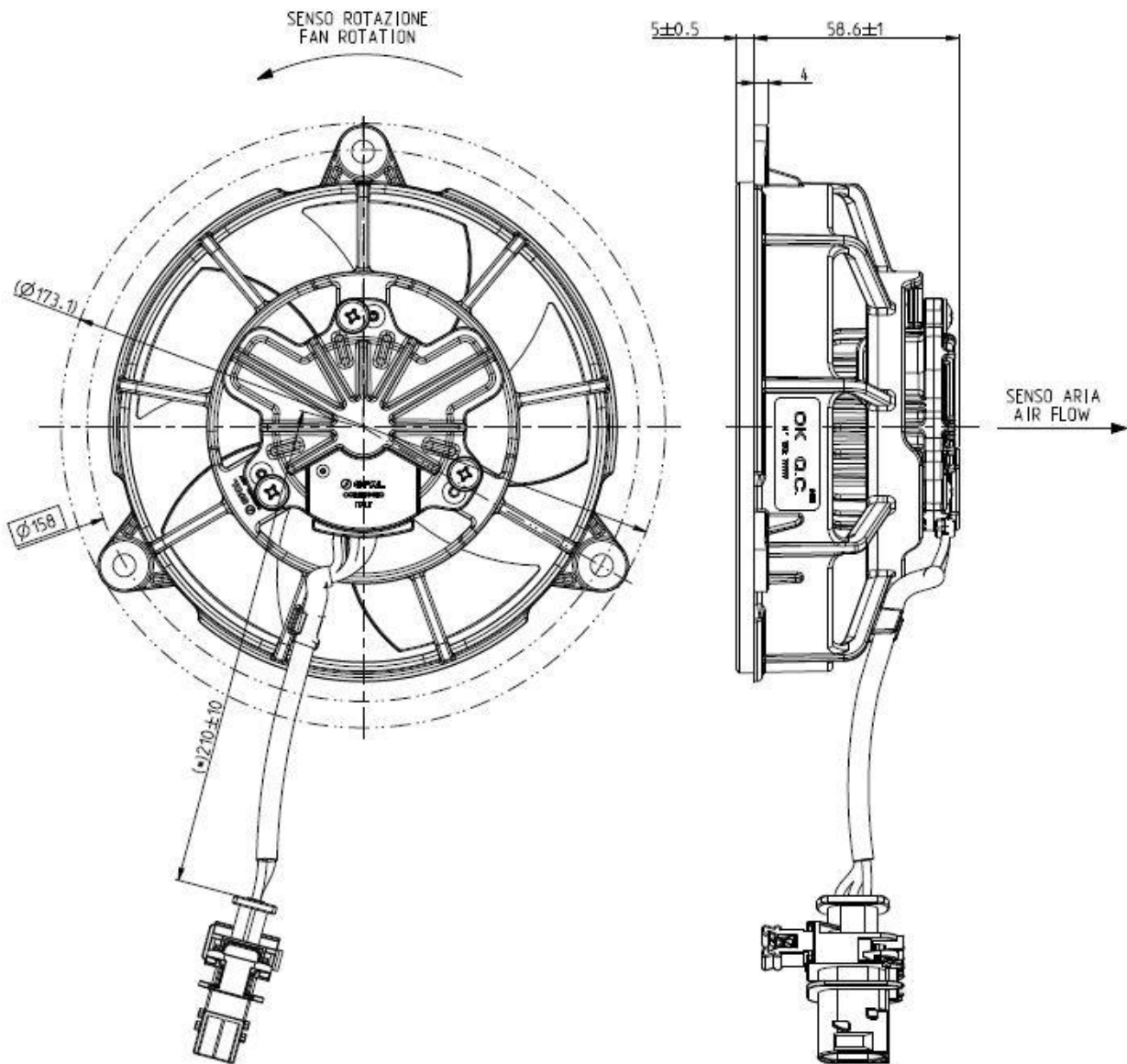

Fixing recommendation: use M5 bolts for fixing. Nominal tightening torque 3 +1/0 Nm
 Nominal torque defined for brand new, clean and lubricant-free bolts.

Any unauthorized use and / or copy of this document is strictly forbidden

5 Connector and wires

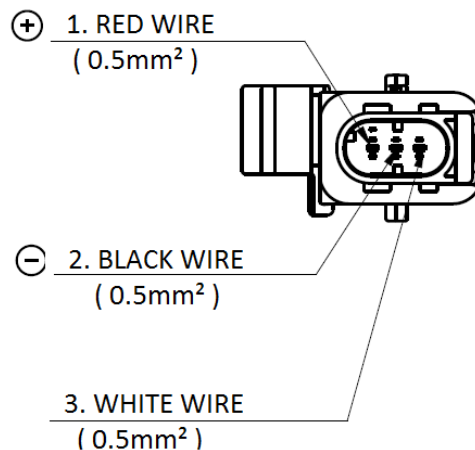

Connector : AMP SERIES HDSCS GRUPP A - Part number : 1-1670730-1				
Identification (*)	+D	-D	PWM* / E*	/
Pin number	1	2	3	/
Wire Color	Red	Black	White	/
Sealing p/n	963530-1	963530-1	963530-1	/
Pin p/n	964269-2	964269-2	964269-2	/
Section [mm ²]	0.5	0.5	0.5	/

For abbreviations see chapter **8.2 Drive pin functions**

NOTE: Never handle the fan module via the cable harness

6 Further Features

Compliance		ECE Reg. 10-04 and updates - Automotive EMC directive. 2002/95/EC RoHS - Hazardous Substances 2000/53/EC and updates - End-of Life Vehicle
Ingress Protection		IP 68 and IP6K9K design
Allowed power supply max ripple	rms	1 % - contact SPAL for special needs
Fuse protection		An automotive fuse according ISO8820 must be chosen and used by the customer in the application wire harness. Each drive must be protected by the unique proper fuse (e.g. in case of double fan modules, two fuses are needed)

7 Measurement conditions

The below conditions are assumed:

- $T_{AMB} = 20\text{ °C} \pm 5\text{ °C}$ and
- Supply voltage **UB** = 13.0 V at the **Drive** connector

unless otherwise specified.

Any unauthorized use and / or copy of this document is strictly forbidden

8 Hardware functions

8.1 Drive diagram

The Drive diagram is shown below.

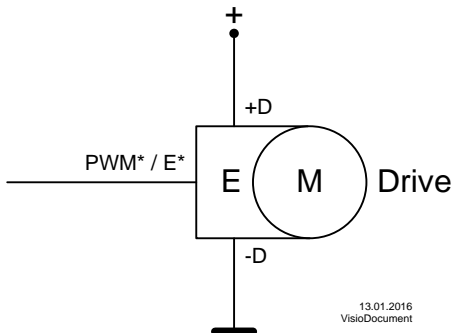

E stands for integrated electronics. M stands for motor. Drive stands for motor with axial integrated electronics.

8.2 Drive pin functions

The electrical Drive interface consists of 3 pins:

Power pins:

- supply voltage plus: +D
- supply voltage minus: -D

Signal pins:

Combined input and output: digital PWM input with feedback output / active low: PWM* / E*

The signal pin PWM* / E* is used to control the Drive, it is the control input.

In this application also permanent recessive level on PWM* / E* will put the Drive into Drive mode Run mode.

9 Drive interface

The Drive interface, i.e. the connections between the CCU (Custom Control Unit) and the Drive, is depicted in the following picture.

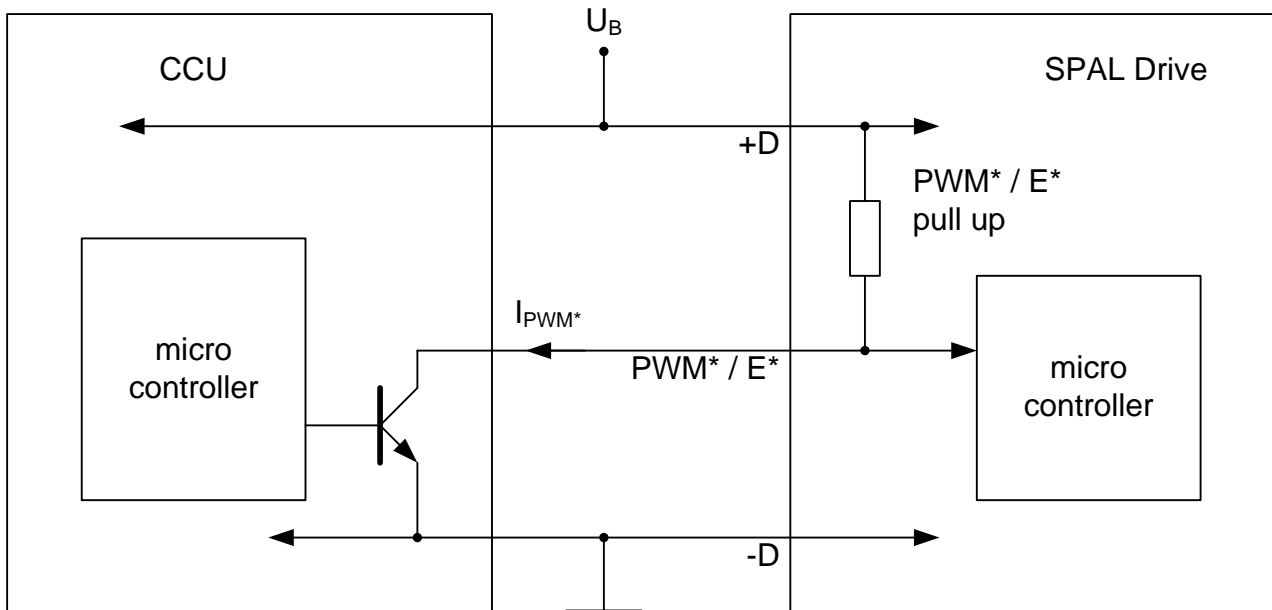

13.01.2016
VisioDocument

The CCU electronics and the Drive electronics are connected via one unidirectional lines.

The PWM signal for the input PWM* / E* comes from the CCU electronics and uses a pull up resistor (PWM* / E* pull up) located in the Drive electronics to determine the recessive level.

This pull up resistor is connected to the supply voltage plus: +D / UB.

The dominant level on the input PWM* / E* is low level, provided by the switching to ground stage depicted in above figure. as a bipolar npn transistor in the CCU.

10 Interface hardware for Digital control: pin PWM* / E*

Parameters	Min	Typical	Max	Unit	Denomination
PWM* / E* frequency range	20		150	Hz	f _{PWM 1)}
PWM* / E* duty cycle range	0		100	%	dc _{min} .. dc _{max}
PWM* / E* high level voltage	U _B * 0.65			V	U _{PWMH}
PWM* / E* low level voltage			U _B * 0.40	V	U _{PWML}
PWM* / E* resolution		1		%	dc _{resol}
PWM* / E* accuracy		1		%	dc _{accu}
PWM* / E* current	-10 %	5.9	+10 %	mA	I _{PWM}
PWM* / E* feedback voltage dominant level			1	V	U _{PWM* / E*}
PWM* / E* feedback current			10	mA	I _{FO}
PWM* / E* wake up voltage	U _B - 2 V			V	U _{PWMWU}
PWM* / E* wakeup pulse	150			µs	T _{wakeup}
PWM* pull up		2.2		kΩ	

Any unauthorized use and / or copy of this document is strictly forbidden

11 Software functions

11.1 Drive modes

The Drive has different working modes related mainly to the Drive current consumption:

1. Electronics active mode
2. Run mode
3. Failure mode

The Drive mode changes accordingly to the control input duty cycle on pin PWM* / E*.

No.	Drive mode	Current consumption	Drive speed
1	Electronics active mode	< 40 mA	0
2	Run mode	depending on the requested speed and on the load	depending on the PWM duty cycle
3	Failure mode	< 40 mA	depending on the failure

The Electronics is always in active mode.

In this application also permanent recessive level on PWM* / E* will put the Drive into Drive mode Run mode. The Drive never goes into the Drive mode Quiescent current mode.

The Drive mode Failure mode is entered in case of failures of the Drive (see chapter 11.4).

11.2 Digital control: transfer function PWM input

The transfer function PWM input is the relation between the Drive speed and the duty cycle on the pin digital PWM input / active high: PWM* / E*.

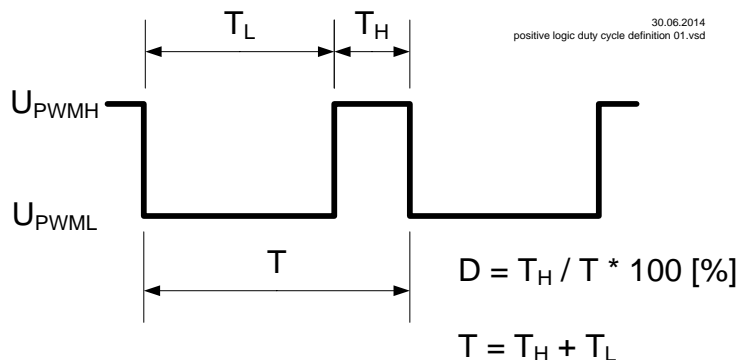

It is called "positive logic duty cycle definition".

Considering this definition,

- continuous low voltage is 0 % duty cycle (dominant level)
- continuous high voltage is 100 % duty cycle (recessive level)

Based on this duty cycle definition the transfer function PWM input is shown in the following figure.

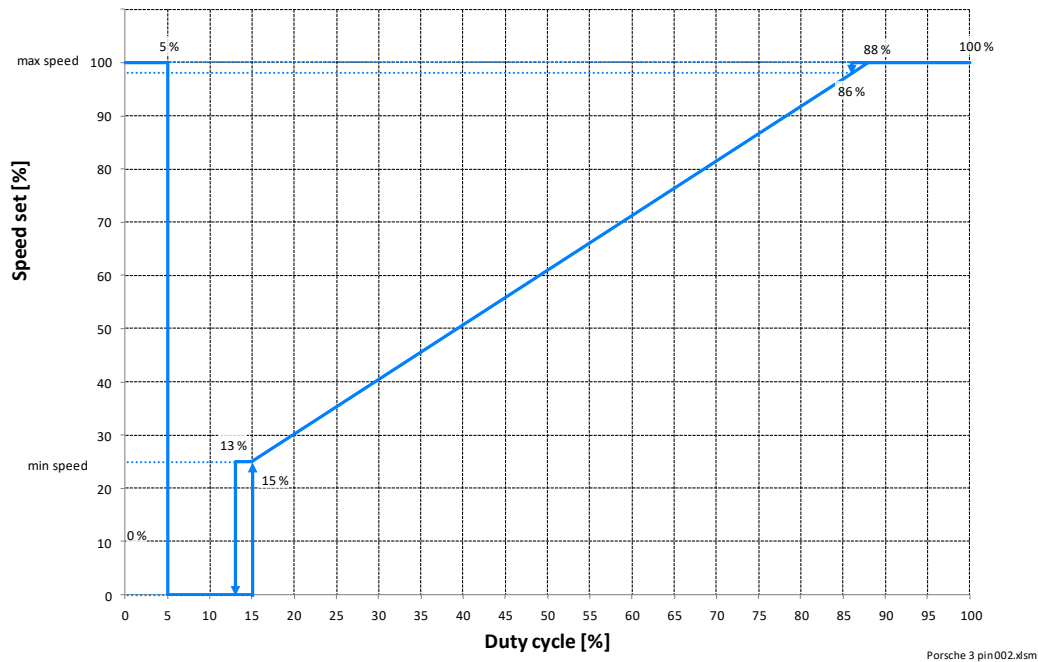

Figure 1: Transfer function Drive speed versus PWM duty cycle

In the range from 0 % to 5 % and from 95 % to 100 % duty cycle the Drive goes to full speed after 8 s. In this way the failure modes “short circuit to ground of the PWM line” and “interrupted PWM line” yield into full speed of the Drive.

The electronics is always in active mode (it is never in quiescent mode) once connected to power supply. Therefore it is suggested the disconnection of the fan module by means of a relay in order to avoid current draining from the vehicle battery when vehicle is not in use. After the application of the power via the relay and no PWM signal applied (100 % duty cycle, continuous high voltage) the Drive will go into Run mode Electronics active mode.

11.3 PWM signal plausibility check

The PWM signal on the control input PWM* / E* is measured by the Drive electronics. For improving noise to signal ratio the PWM signal becomes only valid and is only used to set the speed of the Drive when a sufficient number of consecutive duty cycle measurements are equal. This plausibility test slightly delays the response to the change of the duty cycle PWM value. This delay is in the range of 0.2 s or less.

11.4 Drive mode Failure modes

There are the following cases where the Drive will go into Failure mode and stop the Drive:

Failure modes	Handling of the failure	Notification (*)
Drive blocked	In case of detection of a rotor locked the following strategy is used: a delay of 5 s till the next start attempt is introduced. If this start attempt fails again a delay increased by further 5 s till the next start attempt is introduced. This delay increase is repeated till the delay between the attempts is 25 s. Then this delay is kept for ever as long a valid PWM duty cycle is detected which asks the Drive to run	n/a
Drive overloaded	Fan speed is reduced in case of overload detection by means of current draw measurement.	n/a
Over current	The Drive will stop if the over current safety threshold is reached.	
Drive overheated	Fan speed is reduced in case of overheating detection (derating). Over the max operating temperature, the Drive will stop.	n/a

Any unauthorized use and / or copy of this document is strictly forbidden

Under and Over voltage	If the supply voltage is outside the specified range the Drive will stop.	n/a
Internal Drive failure	The Drive will stop if a failure is detected during the startup self check procedure.	n/a

In all cases the Drive tries to recover from failures when a valid PWM signal is detected which asks the Drive to run.

(*) Notification is not available as no feedback is provided to the CCU.

12 Units and acronyms

Unit		Physical Quantity	Prefix	Dimension	
%	percent	Proportionality	M	10 ⁶	mega
Ω	Ohm	Electrical Resistance	k	10 ³	kilo
°C	degree Celsius	Temperature	m	10 ⁻³	milli
A	Ampere	Current	μ	10 ⁻⁶	micro
h	hours	Time	n	10 ⁻⁹	nano
dBA	decibel (A-weighting)	Sound pressure level	p	10 ⁻¹²	pico
Hz	Hertz	Frequency			
min	minute	Time			
Pa	Pascal	Pressure			
rpm	Revolutions per minute	Rotation frequency			
s	second	Time			
V	Volt	Voltage			
W	Watt	Power			

Table 1: Units of measurements

Key Word	Description
AMPL_IN	Amplitude PWM input signal
CCU	Custom Control Unit
Drive	Motor with axially integrated electronics
IGN	Ignition (KL15)
PWM	Pulse Width Modulation
R _i	Input Resistance
SBL	Sealed brushless
T	Temperature
T _{AMB}	Ambient Temperature
U _B	Supply voltage
U _n	Nominal supply Voltage
rms	root mean square

13 Document change history

Initial document author: document author

Latest revision: 000

Document author	Date	Revision	Comment
SPAL TEAM	30.09.2020	000	Initial Version.

Table 2: Document change history

Document status: released

Any unauthorized use and / or copy of this document is strictly forbidden

14	Sommario	
1	General	1
2	Features	1
3	Air performance at maximum speed	2
4	Mechanical data	3
5	Connector and wires	4
6	Further Features	4
7	Measurement conditions	4
8	Hardware functions	5
8.1	Drive diagram	5
8.2	Drive pin functions	5
9	Drive interface	5
10	Interface hardware for Digital control: pin PWM* / E*	6
11	Software functions	7
11.1	Drive modes	7
11.2	Digital control: transfer function PWM input	7
11.3	PWM signal plausibility check	8
11.4	Drive mode Failure modes	8
12	Units and acronyms	9
13	Document change history	9
14	Sommario	10

Any unauthorized use and / or copy of this document is strictly forbidden